

**SN74BCT756**  
**OCTAL BUFFER/DRIVER**  
**WITH OPEN-COLLECTOR OUTPUTS**  
 SCBS056B – OCTOBER 1990 – REVISED JULY 1997

- BiCMOS Design Significantly Reduces  $I_{CCZ}$
- ESD Protection Exceeds 2000 V Per MIL-STD-883, Method 3015; Exceeds 200 V Using Machine Model (C = 200 pF, R = 0)
- Open-Collector Outputs Drive Bus Lines or Buffer Memory Address Registers
- Package Options Include Plastic Small-Outline Packages (DW) and Standard Plastic 300-mil DIPs (N)

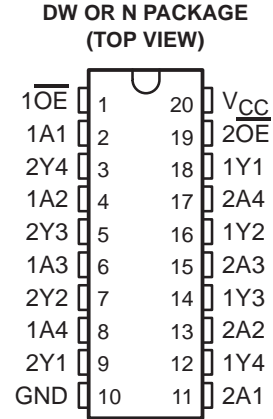

**description**

This octal buffer and line driver is designed specifically to improve both the performance and density of 3-state memory address drivers, clock drivers, and bus-oriented receivers and transmitters. The SN74BCT756, SN74BCT757, and SN74BCT760 provide the choice of selected combinations of inverting outputs, symmetrical output-enable ( $\overline{OE}$ ) inputs, and complementary OE and  $\overline{OE}$  inputs.

The SN74BCT756 is characterized for operation from 0°C to 70°C.

**FUNCTION TABLE**

INPUTS		OUTPUT
$\overline{OE}$	A	Y
H	X	H
L	L	H
L	H	L

**logic symbol†**

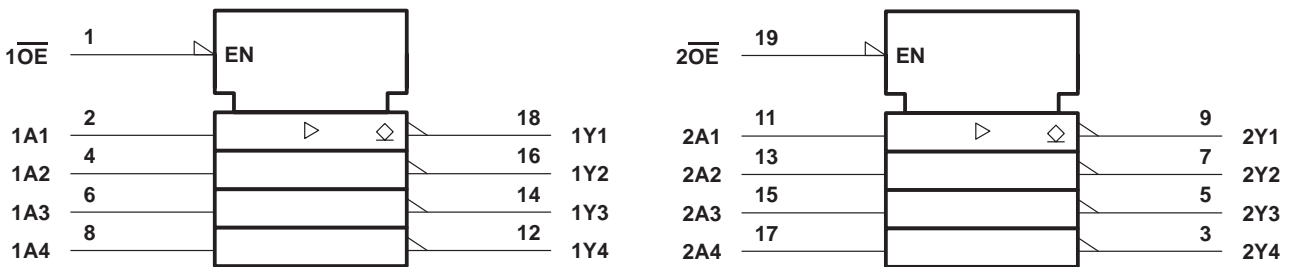

† This symbol is in accordance with ANSI/IEEE Std 91-1984 and IEC Publication 617-12.



Please be aware that an important notice concerning availability, standard warranty, and use in critical applications of Texas Instruments semiconductor products and disclaimers thereto appears at the end of this data sheet.

PRODUCTION DATA information is current as of publication date. Products conform to specifications per the terms of Texas Instruments standard warranty. Production processing does not necessarily include testing of all parameters.



POST OFFICE BOX 655303 • DALLAS, TEXAS 75265

Copyright © 1997, Texas Instruments Incorporated

**SN74BCT756**  
**OCTAL BUFFER/DRIVER**  
**WITH OPEN-COLLECTOR OUTPUTS**  
 SCBS056B – OCTOBER 1990 – REVISED JULY 1997

**logic diagram (positive logic)**

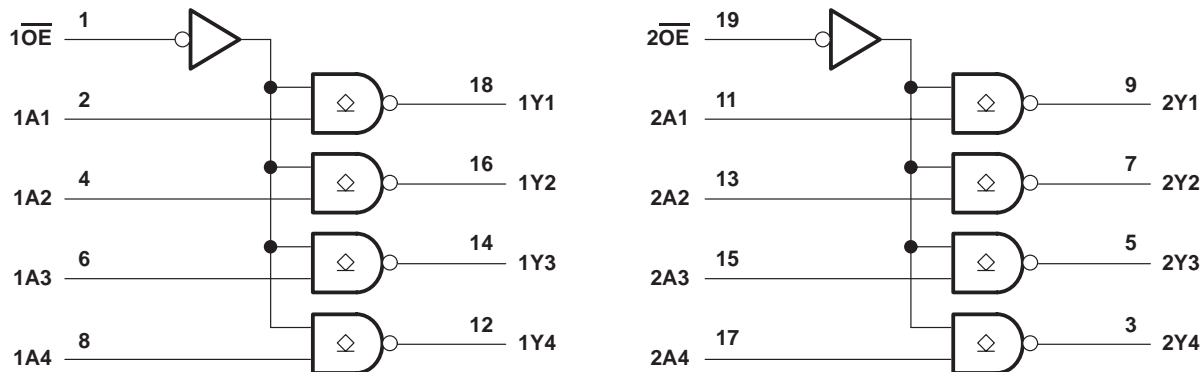

**absolute maximum ratings over operating free-air temperature range (unless otherwise noted)†**

Supply voltage range, $V_{CC}$ .....	-0.5 V to 7 V
Input voltage range, $V_I$ .....	-0.5 V to 7 V
Input current range, $I_I$ .....	-30 mA to 5 mA
Voltage range applied to any output in the disabled or power-off state, $V_O$ .....	-0.5 V to 5.5 V
Voltage range applied to any output in the high state, $V_O$ .....	-0.5 V to $V_{CC}$
Current into any output in the low state .....	128 mA
Package thermal impedance, $\theta_{JA}$ (see Note 1): DW package .....	97°C/W
N package .....	67°C/W
Storage temperature range, $T_{stg}$ .....	-65°C to 150°C

† Stresses beyond those listed under “absolute maximum ratings” may cause permanent damage to the device. These are stress ratings only, and functional operation of the device at these or any other conditions beyond those indicated under “recommended operating conditions” is not implied. Exposure to absolute-maximum-rated conditions for extended periods may affect device reliability.

NOTE 1: The package thermal impedance is calculated in accordance with JESD 51.

**recommended operating conditions**

		MIN	NOM	MAX	UNIT
$V_{CC}$	Supply voltage	4.5	5	5.5	V
$V_{IH}$	High-level input voltage	2			V
$V_{IL}$	Low-level input voltage			0.8	V
$V_{OH}$	High-level output voltage			5.5	V
$I_{IK}$	Input clamp current			-18	mA
$I_{OL}$	Low-level output current			64	mA
$T_A$	Operating free-air temperature	0		70	°C



**SN74BCT756**  
**OCTAL BUFFER/DRIVER**  
**WITH OPEN-COLLECTOR OUTPUTS**  
 SCBS056B – OCTOBER 1990 – REVISED JULY 1997

**electrical characteristics over recommended operating free-air temperature range (unless otherwise noted)**

PARAMETER	TEST CONDITIONS		MIN	TYP†	MAX	UNIT	
$V_{IK}$	$V_{CC} = 4.5\text{ V}$ ,	$I_I = -18\text{ mA}$			-1.2	V	
$I_{OH}$	$V_{CC} = 4.5\text{ V}$ ,	$V_{OH} = 5.5\text{ V}$			0.1	mA	
$V_{OL}$	$V_{CC} = 4.5\text{ V}$ ,	$I_{OL} = 64\text{ mA}$		0.42	0.55	V	
$I_I$	$V_{CC} = 5.5\text{ V}$ ,	$V_I = 7\text{ V}$			0.1	mA	
$I_{IH}$	$V_{CC} = 5.5\text{ V}$ ,	$V_I = 2.7\text{ V}$			20	$\mu\text{A}$	
$I_{IL}$	$V_{CC} = 5.5\text{ V}$ ,	$V_I = 0.5\text{ V}$			-1	mA	
$I_{CC}$	$V_{CC} = 5.5\text{ V}$ ,	Outputs open	Outputs high		21	33	mA
			Outputs low		55	86	
			$\overline{OE}$ disable		6	10	
$C_i$	$V_{CC} = 5\text{ V}$ ,	$V_I = 2.5\text{ V}$ or $0.5\text{ V}$		6		pF	
$C_o$	$V_{CC} = 5\text{ V}$ ,	$V_I = 2.5\text{ V}$ or $0.5\text{ V}$		10		pF	

† All typical values are at  $V_{CC} = 5\text{ V}$ ,  $T_A = 25^\circ\text{C}$ .

**switching characteristics over recommended ranges of supply voltage and operating free-air temperature,  $C_L = 50\text{ pF}$  (unless otherwise noted) (see Figure 1)**

PARAMETER	FROM (INPUT)	TO (OUTPUT)	$V_{CC} = 5\text{ V}$ , $C_L = 50\text{ pF}$ , $R_1 = 500\ \Omega$ , $R_2 = 500\ \Omega$ , $T_A = 25^\circ\text{C}$			$V_{CC} = 4.5\text{ to }5.5\text{ V}$ , $C_L = 50\text{ pF}$ , $R_1 = 500\ \Omega$ , $R_2 = 500\ \Omega$ , $T_A = \text{MIN to MAX}^\ddagger$		UNIT
			MIN	TYP	MAX	MIN	MAX	
$t_{PLH}$	A	Y	6.2	8.5	10.5	6.2	11.3	ns
$t_{PHL}$			0.5	2	4.1	0.5	4.2	
$t_{PLH}$	$\overline{OE}$	Y	8.2	12.5	14.8	8.2	16.5	ns
$t_{PHL}$			3.4	6.8	9.2	3.4	10.3	

‡ For conditions as MIN or MAX, use the appropriate value specified under recommended operating conditions.

PARAMETER MEASUREMENT INFORMATION

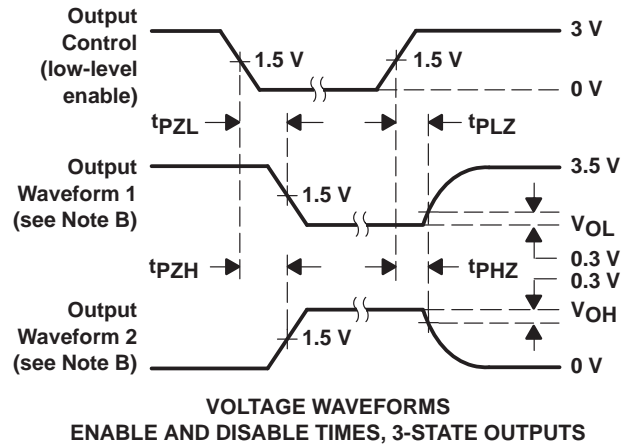
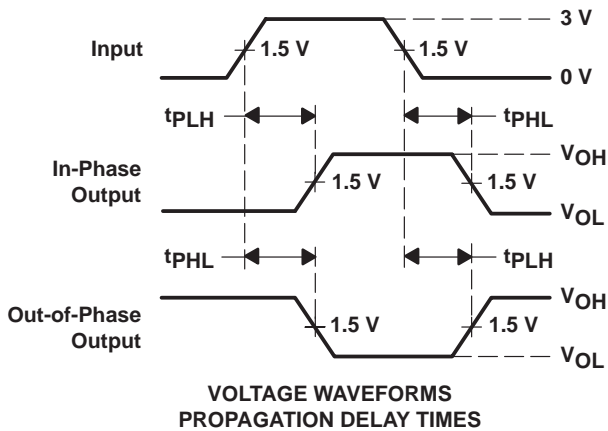
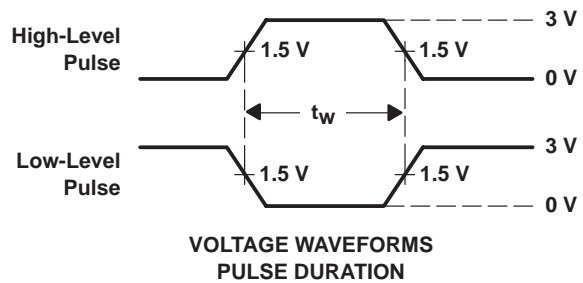
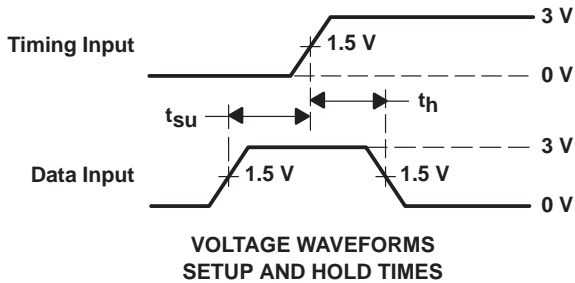
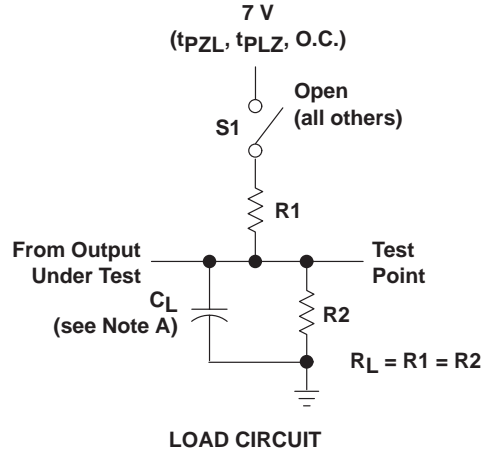

- NOTES: A. C<sub>L</sub> includes probe and jig capacitance.  
 B. Waveform 1 is for an output with internal conditions such that the output is low except when disabled by the output control. Waveform 2 is for an output with internal conditions such that the output is high except when disabled by the output control.  
 C. All input pulses are supplied by generators having the following characteristics: PRR ≤ 10 MHz, t<sub>r</sub> = t<sub>f</sub> ≤ 2.5 ns, duty cycle = 50%.  
 D. The outputs are measured one at a time with one input transition per measurement.

Figure 1. Load Circuit and Voltage Waveforms

## IMPORTANT NOTICE

Texas Instruments and its subsidiaries (TI) reserve the right to make changes to their products or to discontinue any product or service without notice, and advise customers to obtain the latest version of relevant information to verify, before placing orders, that information being relied on is current and complete. All products are sold subject to the terms and conditions of sale supplied at the time of order acknowledgement, including those pertaining to warranty, patent infringement, and limitation of liability.

TI warrants performance of its semiconductor products to the specifications applicable at the time of sale in accordance with TI's standard warranty. Testing and other quality control techniques are utilized to the extent TI deems necessary to support this warranty. Specific testing of all parameters of each device is not necessarily performed, except those mandated by government requirements.

CERTAIN APPLICATIONS USING SEMICONDUCTOR PRODUCTS MAY INVOLVE POTENTIAL RISKS OF DEATH, PERSONAL INJURY, OR SEVERE PROPERTY OR ENVIRONMENTAL DAMAGE ("CRITICAL APPLICATIONS"). TI SEMICONDUCTOR PRODUCTS ARE NOT DESIGNED, AUTHORIZED, OR WARRANTED TO BE SUITABLE FOR USE IN LIFE-SUPPORT DEVICES OR SYSTEMS OR OTHER CRITICAL APPLICATIONS. INCLUSION OF TI PRODUCTS IN SUCH APPLICATIONS IS UNDERSTOOD TO BE FULLY AT THE CUSTOMER'S RISK.

In order to minimize risks associated with the customer's applications, adequate design and operating safeguards must be provided by the customer to minimize inherent or procedural hazards.

TI assumes no liability for applications assistance or customer product design. TI does not warrant or represent that any license, either express or implied, is granted under any patent right, copyright, mask work right, or other intellectual property right of TI covering or relating to any combination, machine, or process in which such semiconductor products or services might be or are used. TI's publication of information regarding any third party's products or services does not constitute TI's approval, warranty or endorsement thereof.